



DOI: 10.31643/2025/6445.08

Metallurgy



# The influence of the hydrogenation process on the microstructure and properties of metallic materials

Małgorzata Rutkowska-Gorczyca, Mateusz Dziubek, Marcin Wiśniewski

Wroclaw University of Science and Technology, Wroclaw, Poland

\* Corresponding author email: bagdaulet\_k@satbayev.university

<p>Received: January 3, 2024 Peer-reviewed: January 9, 2024 Accepted: March 5, 2024</p>	<p><b>ABSTRACT</b> Hydrogen, which belongs to the group of the smallest elements, can freely penetrate the structure of metallic materials and cause enormous damage. This phenomenon may occur due to various conditions and may have different effects on the properties of materials. Understanding these mechanisms is important in the era of changing to alternative energy sources. This situation may occur in combustion engines powered by hydrogen-enriched fuel. The work analyzed the impact of various hydrogenation processes on the properties of aesthetic steel, which is allergic to the formation of carbides at the grain boundaries, such a microstructure is intended to simulate the least favorable working conditions. The work was aimed at evaluating the effects of different hydrogenation methods on changes in the properties of the AISI 310s steel membrane. In the work, electrolytic hydrogenation and heat treatment procedures in a hydrogen atmosphere were used. Investigations of changes in material properties included microhardness and in-situ strength tests in a scanning electron microscope chamber. Research has shown that both processes increase the hardness of materials and change the characteristics of stretching curves.</p>
	<p><b>Keywords:</b> hydrogen process, metallic membranes, material properties</p>
<p><b>Małgorzata Rutkowska-Gorczyca</b></p>	<p><b>Information about authors:</b> <i>PhD in Mechanics, Associate Professor, Department of Automotive Engineering, Wroclaw University of Science and Technology, Wyb. Wyspianskiego 27, 50-370 Wroclaw, Poland. Email: malgorzata.rutkowska-gorczyca@pwr.edu.pl</i></p>
<p><b>Mateusz Dziubek</b></p>	<p><i>MSc, Department of Automotive Engineering, Wroclaw University of Science and Technology, Wyb. Wyspianskiego 27, 50-370 Wroclaw, Poland. Email: mateusz.dziubek@pwr.edu.pl</i></p>
<p><b>Marcin Wiśniewski</b></p>	<p><i>Engineer, Department of Automotive Engineering, Wroclaw University of Science and Technology, Wyb. Wyspianskiego 27, 50-370 Wroclaw, Poland. Email: 255206@student.pwr.edu.pl</i></p>

## Introduction

The problem of hydrogen embrittlement is quite a dangerous phenomenon in the case of metals and their alloys [[1], [2]]. In technological and metal processing processes (Xi et al., 2023), the mechanical properties and corrosion resistance of materials may deteriorate due to the impact of the hydrogen environment [[4], [5], [6]]. The negative impact of hydrogen on metallic materials affects a wide range of different industries such as metallurgy, petrochemicals, aviation, and other fields. The threats of hydrogen to metals include hydrogen-induced cracking, high-temperature hydrogen corrosion [[7], [8]], hydride and hydrogen-to-martensitic transformation, etc. Research on hydrogen embrittlement has been ongoing for a long time, but the mechanism of microstructure interaction with hydrogen and damage caused by

the presence of hydrogen requires numerous additional studies.

A very interesting issue related to alternative methods of reducing the negative impact of transport on exhaust emissions into the environment is the use of combustion engines powered by hydrogen-enriched fuel. Hydrogen engines open up new perspectives for the automotive sector but also pose new design problems to solve [[9], [10], [11], [12], [13]]. A major threat that may damage an engine operating in a hydrogen environment is the phenomenon of hydrogen embrittlement of metallic materials. The influence of hydrogen causes a weakening of the structure of metallic materials and an increase in susceptibility to brittle fracture. Hydrogen, which belongs to the group of the smallest elements, can freely penetrate the structure of the material. The diffusion of hydrogen into the material causes changes in the material's microstructure and

permanently reduces the strength and plastic properties of the material. The greatest threat is the creation of conditions initiating brittle cracking of materials after some time of exposure to loads.

Various materials are used to build engines, one of the groups of materials used due to their high strength and corrosion resistance is austenitic steel. AISI 310s heat-resistant steel is an austenitic chrome-nickel grade with increased nickel content, characterized by high strength, ductility, resistance to air and oxidizing atmosphere in the high-temperature range up to 1050 °C. Steel is used for mechanically loaded parts that operate at high temperatures. Improper technological processes and working conditions at elevated temperatures may cause the formation of hard phases in austenitic steels. Depending on the chemical composition of the steel,  $M_{23}C_6$  carbides may be formed, which significantly weaken the properties of this material [[12], [13]]. The work presents the influence of various methods of the hydrogenation process on the surface and properties of AISI 310s steel, which is allergic to the formation of carbides  $M_{23}C_6$ .

**Research problem.** As energy management methods change to more ecological ones, hydrogen will play a huge role in this topic. The topic of hydrogen will be considered at many levels: new mechanisms, new theories, new phenomena of hydrogen embrittlement of metal, steel or light alloy, research and development of hydrogen removal process in metal, the interaction between

hydrogen, fatigue and crack growth, action laws of other hydrogen-induced failure forms, corrosion issues related to hydrogen and fatigue, fracture and failure of hydrogen charging metals. This paper presents the effect of various hydrogenation processes, on surface changes and the strength of ASIA 310s steel membranes sensitized by intergranular corrosion. The study showed the effect of this process on the strength of the material.

### Material

The material in the form of commercially available AISI 310s steel was selected for the tests (jfs-steel.com). The tested steel showed a microstructure, equiaxed alloy austenite grains with precipitations of carbides forming a shell at the grain boundaries (Fig. 1.). In the delivery state, according to the supplier, the material was characterized by the chemical composition given in tab. 1. and showed the properties presented in tab. 2. Membranes for the tests were prepared in the form of plates with a thickness of 0.7 mm, dimensions shown in Fig. 2. The area of interaction with the electrolyte during electrochemical processes was about 550 mm<sup>2</sup> and was the same for each sample. The surface of the materials before the electrochemical process was cleaned in an ultrasonic scrubber in an acetone solution for 10 minutes.

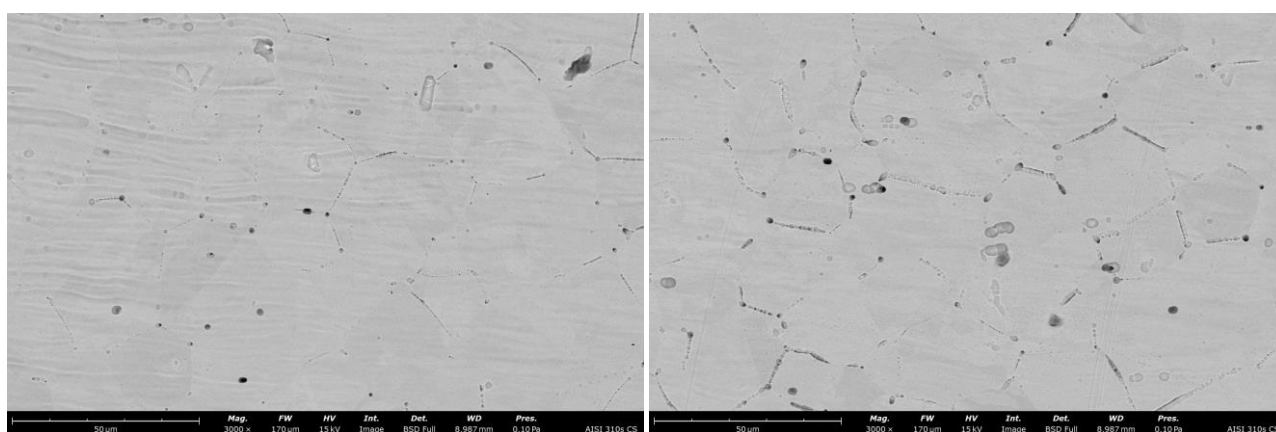

**Fig. 1** - Microstructure of alloyed austenite with evolved carbons at grain boundaries in AISI 310s steel in the supply state. SEM

**Table 1** - Chemical composition of steel AISI 310s

AISI 310s	C <0.2	Mn<1.5	Si<1.0	V <0.2	W <0.5
P<0.045	S<0.030	Cr 22.0-25.0	Ni 17.0-20.0	Mo <0.5	Fe rest

**Table 2** - Mechanical properties of steel AISI 310s

tensile strength Rm	Elongation A	Hardness
500-700 MPa	33%	192HB

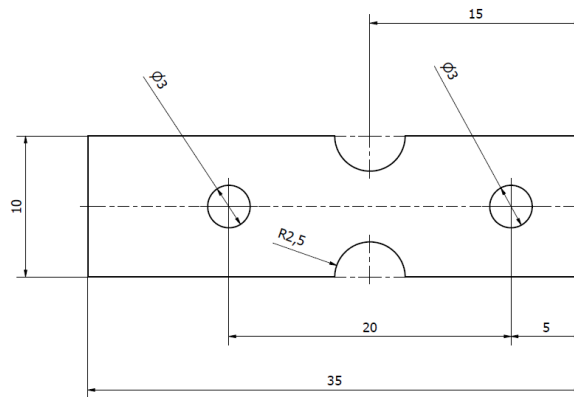
**Fig. 2** - Austenitic steel membrane dimensions

### Method

The hydrogen charging process was carried out using a BioLogis SP50ze potentiostat/galvanostat. Current waveforms were carried out in an electrolyte with a concentration of 0.5 M H<sub>2</sub>SO<sub>4</sub> and pH 1. Voltammetry (CV measurement) was carried out in a three-electrode system, where the metallic membrane was the working electrode. The hydrogen charging process included two ranges: 25 cycles (1 hour) and 50 cycles (2 hours). The system was cyclically loaded with current between a potential of -0.200 V and -1.4 V, with a scanning rate of 20 mV/s. The measurement procedure began with a 10-minute open circuit measurement (OCV) in the electrode system used, based on which the open circuit potential  $E_{we}$  was determined, which was used to determine the range of the voltammetry process. The open circuit voltage consists of the period during which no potential or current is applied to the working electrode. The cell is disconnected from the power amplifier. Potential measurements are available on the cell. Thus, the evolution of the resting potential can be recorded. This period is commonly used as a preconditioning time or to equilibrate an electrochemical cell.

CV voltammetry measurements were performed in the range below the open circuit value  $E_{we}$  to eliminate the oxidation process and force the hydrogen evolution process. Cyclic voltammetry (CV) is the most widely used technique for acquiring qualitative information about electrochemical reactions. CV provides information on redox processes, heterogeneous electron-transfer

reactions and adsorption processes. It offers a rapid location of the redox potential of the electroactive species. A CV consists of scanning linearly the potential of a stationary working electrode using a triangular potential waveform. During the potential sweep, the potentiostat measures the current resulting from electrochemical reactions. The cyclic voltammogram is a current response as a function of the applied potential.

Heat treatment tests were carried out in resistance furnaces in an air atmosphere and a furnace with a protective atmosphere (Czelok furnace). Argon gas with a 5% hydrogen admixture was selected for testing in a hydrogen atmosphere, the flow was set at 3 dm<sup>3</sup> per minute. The samples were heated in a hydrogen atmosphere with an oven from 20°C to a temperature of 900°C, at which the samples were kept for 2 hours. After an appropriate time, the samples were removed from the oven, cooled in water and immediately subjected to the tensile process in a Deben Microtest strain gauge holder compatible with the Phenom XL scanning electron microscope. The holder enables strength tests up to 1000N and in-situ observations in scanning microscope mode. Investigations of the surface of the material after hydrogenation were also carried out using scanning electron microscopy methods on a Phenom XL microscope. Then, microhardness measurements were carried out by the PN-EN ISO 6507-1:2018-05 standard using the Vickers method, using a Leco LM-248AT microhardness tester. The measurements were carried out with a load of 300 g, which is equivalent to a force of 2.94 N.

## Research results

### Electrochemical hydrogen charging of AISI 310

Voltammetry measurements CV showed in all cycles similar shape of the curves, during observations the hydrogenation process showed an increasingly intense and violet process of hydrogen evolution in the lower parts of the graph. The most intensive hydrogenation process took place in the range below 0.5 Ewe, numerous hydrogen bubbles were visible, concentrating on the surface of the metallic membrane constituting the working electrode. In subsequent hydrogenation cycles, the

current values decreased in the range of  $-2.5\text{mA/cm}$  to  $-3.5\text{mA/cm}$  for 25 cycles (Fig. 3). For hydrogenation in 50 cycles, the current values were lower and oscillated from  $-3.0\text{mA/cm}$  to  $-6\text{mA/cm}$  (Fig. 4). Differences in the initial values result from differences in the closed-circuit measurement values in a given electrode system. There is a clear tendency to decrease the current values in successive hydrogenation cycles. This proves the changes taking place in the metallic membranes and the change of their electrochemical potentials about the material in the delivery state.

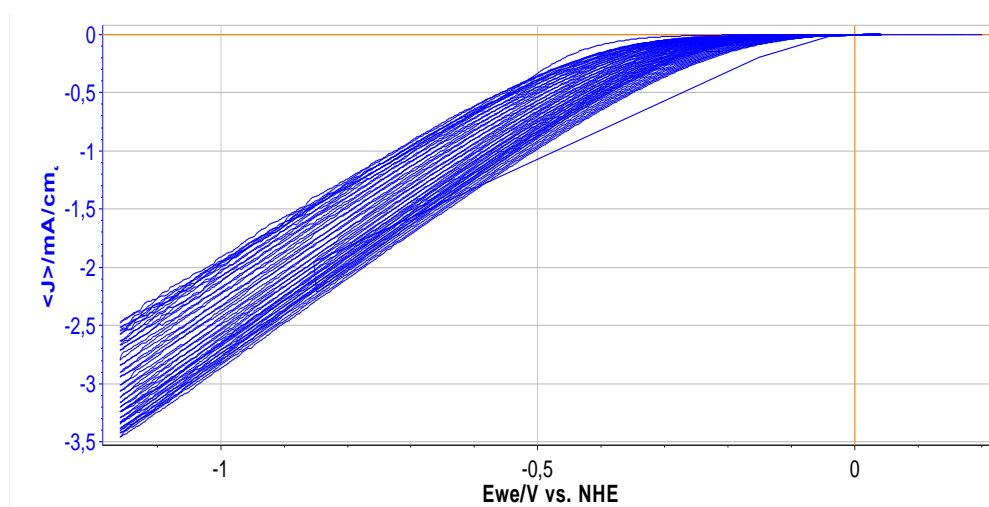

Fig. 3 - Cyclic Voltammetry curve after 25 hydrogen cycles in  $0,5\text{MH}_2\text{SO}_4$

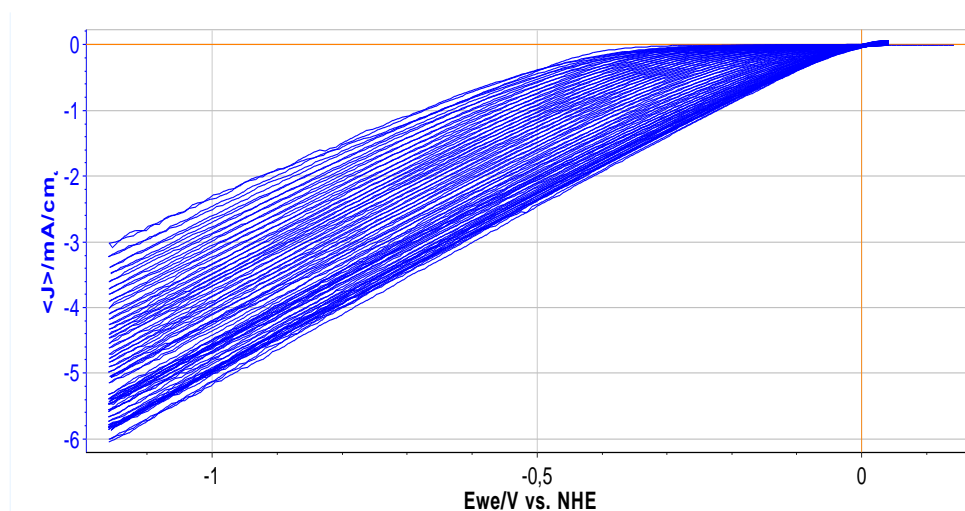
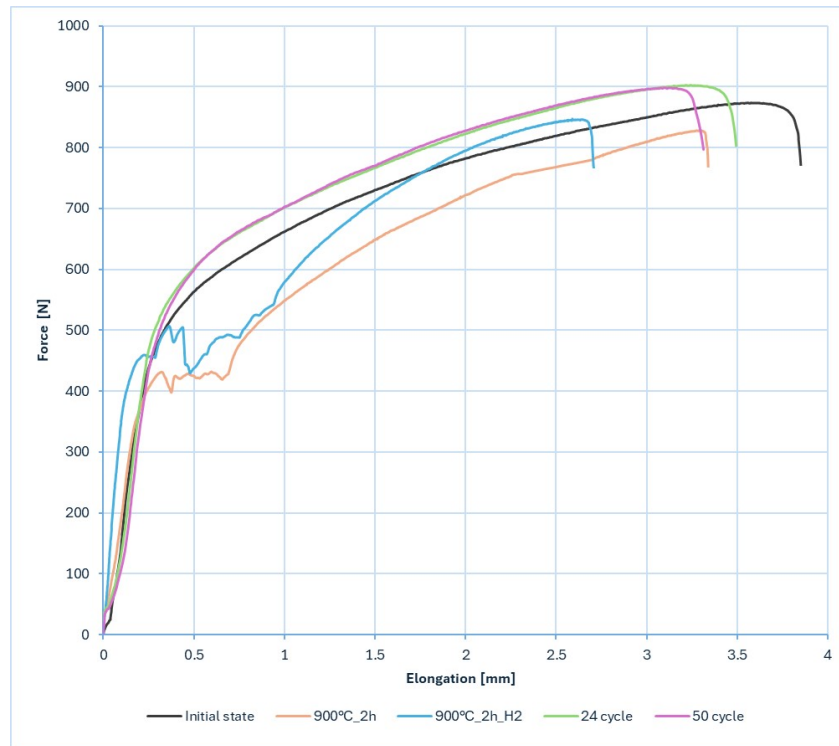

Fig. 4 - Cyclic Voltammetry curve after 50 hydrogen cycles in  $0,5\text{MH}_2\text{SO}_4$



**Fig. 5** - Tensile curves for delivery state and after hydrogenation proces

The samples after the hydrogenation process were subjected to axial tensile testing at a constant speed of 0.5 mm/s inside a scanning electron microscope chamber equipped with a tensile holder with a maximum measurement force of 1 kN. All the tensile tests were conducted in a single setup, creating geometric notches in the central part of the samples. As a result of the tensile testing, the maximum force and elongation were determined, which were considered as comparative values due to the identical geometry of the samples (Fig. 5). The hydrogenation process after 25 and 50 cycles resulted in a slight strengthening of the material, increasing the maximum force value by 3%, which represents a minor change. On the other hand, the elongation value underwent a significant reduction, decreasing by 9% after 25 cycles of hydrogenation and 13% after 50 cycles of hydrogenation compared to the reference state. This indicates a negative impact of the hydrogen environment on AISI 310S steel.

Microhardness tests are one of the simplest methods to determine changes in the form of strengthening in the material after the hydrogenation process. Hardness measurements

were carried out on the surface of the membranes, on the undeformed elements of the sample after both the hydrogenation process. Analysis of the microhardness results showed that the H<sub>2</sub> environment affects the surface hardening of AISI 310s steel (Fig. 6).

An increase in hardness compared to the initial state material was observed in all tested materials. Hydrogen charging in electrolytic processes resulted in an increase in hardness from 154HV0.2 to 162HV0.2. A linear increase in this parameter was observed when the number of cycles was increased to 50, where the hardness increased to 169HV0.2. The hydrogenation process at a temperature of 900°C also increased the hardness to 182HV0.2 for the membrane heated in an oxygen atmosphere and to 179HV0.2 for the environment enriched with hydrogen particles. The reduced hardness of the material after heat treatment in a hydrogen atmosphere seems puzzling, it may be related to the presence of atomic hydrogen, which only changes to a molecular form when the material is loaded and results in increased brittleness.

In the electrochemical hydrogenation process, an increase in hardness was found commensurate with the increasing number of hydrogenation cycles.

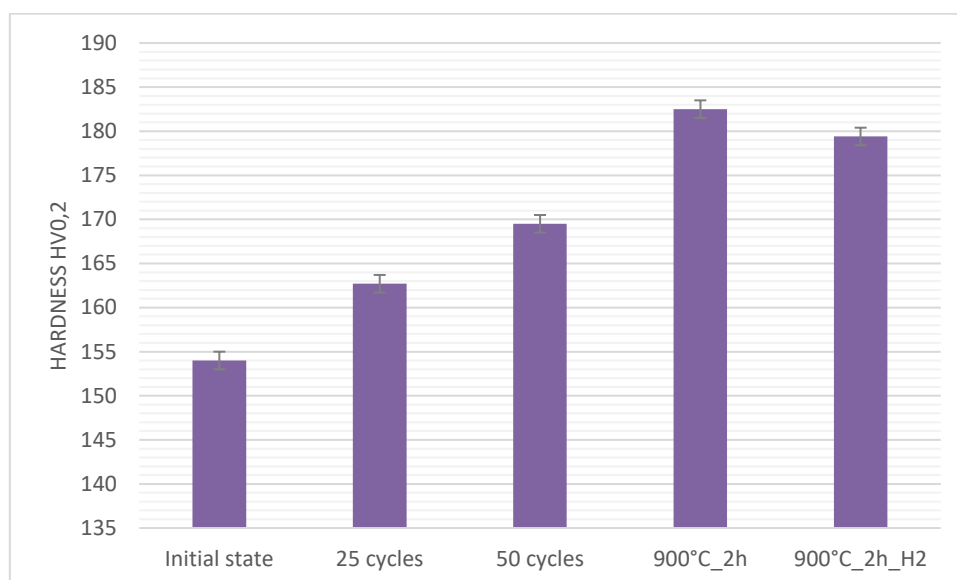

Fig. 6 - Averaged hardness measurement results for metallic membranes

### Research discussion

The steel becomes brittle and more prone to cracking after both treatments, which can result in sudden and uncontrolled material fracture. This effect is most intense in the first hours of hydrogenation. In both cases, the strengthening of the material was found to result from the absorption of hydrogen into the material, independent of the hydrogenation process. This mechanism is known and described as hydrogen strengthening [[14], [15], [16], [17], [18], [19], [20], [21]].

The process of strengthening the material caused by the presence of hydrogen is visible in the stretching curves and the obtained value of the breaking force of the membrane and hardness of the material. Heat treatment in a hydrogen atmosphere significantly increased the hardness of the material, changed the nature of the tensile curves and reduced the value of the breaking force, both for membranes processed in a hydrogen atmosphere and without.

### Conclusions

Based on the conducted research, it was found that AISI 310s steel in a state sensitive to the formation of carbides at the grain boundaries is susceptible to hydrogenation processes. Both during electrochemical processes and heat treatment in a hydrogen atmosphere. This is evidenced by changes on the surface of hydrogenated metallic membranes and the impact on the hardness and strength of this material. The research has revealed very interesting relationships, the results of which leave many new questions to which we will need to know the answers soon. The era of hydrogen technologies is coming quickly.

### Acknowledgements

The authors would like to thank anonymous reviewers and the conference editors for their comments on earlier versions.

**Cite this article as:** Małgorzata Rutkowska-Gorczyca, Mateusz Dziubek, Marcin Wiśniewski. The influence of the hydrogenation process on the microstructure and properties of metallic materials. *Kompleksnoe Ispolzovanie Mineralnogo Syra = Complex Use of Mineral Resources*. 2025; 332(1):90-97. <https://doi.org/10.31643/2025/6445.08>

## Гидрлеу процесінің микроқұрылымға әсері және металл материалдардың қасиеттері

Małgorzata Rutkowska-Gorczyca, Mateusz Dziubek, Marcin Wiśniewski

Вроцлав ғылым және технология университеті, Вроцлав, Польша



<p>Мақала келді: 2 қаңтар 2024 Сараптамадан өтті: 9 қаңтар 2024 Қабылданды: 5 наурыз 2024</p>	<p><b>ТҮЙІНДЕМЕ</b> Ең жеңіл элементтер тобына жататын сүтегі металл материалдардың құрылымына еркін еніп, орасан зор зиян келтіре алады. Бұл құбылыс әртүрлі жағдайларға байланысты болады және материалдардың қасиеттеріне әртүрлі әсер етуі мүмкін. Бұл механизмдерді түсіну баламалы энергия көздеріне көшу кезеңінде маңызды. Бұл жағдай сүтегімен байытылған отынмен жұмыс істейтін ішкі жану қозғалтқыштарында болуы мүмкін. Жұмыста түйіршік шекарасында карбидтердің түзілуіне бейім болатын қасиеттеріне әртүрлі гидрлеу процестерінің әсері талданған, мұндай микроқұрылым ең қолайлы жұмыс жағдайларын модельдеуге арналған. Жұмыс AISI 310s болат мембранасының қасиеттерінің өзгеруіне әртүрлі гидрлеу әдістерінің әсерін бағалауға бағытталған. Жұмыста сүтегі атмосферасында электролиттік гидрлеу және термиялық өңдеу әдістері қолданылды. Материалдардың қасиеттеріндегі өзгерістерді зерттеуге сканерлеуші электронды микроскоп камерасында микроқаттылыққа және заттық беріктікке жасалатын сынақтар кіреді. Зерттеулер екі процестің де материалдардың қаттылығын арттыратынын және созылу қисықтарының сипаттамаларын өзгертетінін көрсетті.</p>
	<p><b>Түйін сөздер:</b> сүтегі процесі, металдық мембраналар, материал қасиеттері</p>
	<p><b>Авторлар туралы ақпарат:</b></p>
<p><b>Małgorzata Rutkowska-Gorczyca</b></p>	<p>Механика ғылымдарының кандидаты, Вроцлав ғылым және технология университетінің автомобиль жасау кафедрасының доценті, Станислав Виспиански жағалауы 27, 50-370, Вроцлав, Польша. Email: malgorzata.rutkowska-gorczyca@pwr.edu.pl</p>
<p><b>Mateusz Dziubek</b></p>	<p>Магистр, Автокөлік техникасы кафедрасы, Вроцлав ғылым және технология университеті, Станислав Виспиански жағалауы 27, 50-370, Вроцлав, Польша. Email: mateusz.dziubek@pwr.edu.pl</p>
<p><b>Marcin Wiśniewski</b></p>	<p>Инженер, Вроцлав ғылым және технология университетінің автомобиль жасау бөлімі, Станислав Виспиански жағалауы 27, 50-370, Вроцлав, Польша. Email: 255206@student.pwr.edu.pl</p>

## Влияние процесса гидрирования на микроструктуру и свойства металлических материалов

Małgorzata Rutkowska-Gorczyca, Mateusz Dziubek, Marcin Wiśniewski

Вроцлавский университет науки и технологий, Вроцлав, Польша

<p>Поступила: 3 января 2024 Рецензирование: 9 января 2024 Принята в печать: 5 марта 2024</p>	<p><b>АННОТАЦИЯ</b> Водород, относящийся к группе мельчайших элементов, может свободно проникать в структуру металлических материалов и наносить огромный вред. Это явление может возникать из-за различных условий и по-разному влиять на свойства материалов. Понимание этих механизмов важно в эпоху перехода на альтернативные источники энергии. Такая ситуация может возникнуть в двигателях внутреннего сгорания, работающих на топливе, обогащенном водородом. В работе проанализировано влияние различных процессов наводороживания на свойства стали, склонной к образованию карбидов по границам зерен. Такая микроструктура призвана моделировать наименее благоприятные условия работы. Целью работы была оценка влияния различных методов гидрирования на изменение свойств мембраны из стали AISI 310s. В работе использовались методы электролитического гидрирования и термообработки в атмосфере водорода. Исследования изменения свойств материалов включали испытания на микротвердость и натурную прочность в камере сканирующего электронного микроскопа. Исследования показали, что оба процесса повышают твердость материалов и изменяют характеристики кривых растяжения.</p>
	<p><b>Ключевые слова:</b> водородный процесс, металлические мембраны, свойства материала.</p>
	<p><b>Информация об авторах:</b></p>
<p><b>Małgorzata Rutkowska-Gorczyca</b></p>	<p>Кандидат механических наук, доцент кафедры автомобильной техники Вроцлавского университета науки и технологий, побережье Станислава Выспяньского 27, 50-370, Вроцлав, Польша. Email: malgorzata.rutkowska-gorczyca@pwr.edu.pl</p>
<p><b>Mateusz Dziubek</b></p>	<p>Магистр, кафедра автомобильной техники, Вроцлавский университет науки и технологий, побережье Станислава Выспяньского 27, 50-370 Вроцлав, Польша. Email: mateusz.dziubek@pwr.edu.pl</p>
<p><b>Marcin Wiśniewski</b></p>	<p>Инженер, кафедра автомобильной техники, Вроцлавский университет науки и технологий, побережье Станислава Выспяньского 27, 50-370, Вроцлав, Польша. Email: 255206@student.pwr.edu.pl</p>

## References

- [1] Hem R, Ann P. Diffusion of hydrogen in metals. 1984; 101.
- [2] Lai CL, Tsay LW, Chen C. Effect of Microstructure on Hydrogen Embrittlement of Various Stainless Steels. *Materials Science and Engineering: A*. 2013; 584:14-20. <https://doi.org/10.1016/j.msea.2013.07.004>
- [3] Xi X, Wu T, Tian Y, Hu J, Huang S, Xie T, Wang J, Chen L. The Role of Reverted Transformation in Hydrogen Embrittlement of a Cu-Containing Low Carbon High Strength Steel. *Journal of Materials Research and Technology*. 2023; 25:5990-5999. <https://doi.org/10.1016/J.JMRT.2023.07.071>
- [4] Jaxymbetova M, Kanayev A, Akhmedyanov A, & Kirgizbayeva K. On the applicability of hardening mechanisms to low-carbon and low-alloy steels. *Kompleksnoe Ispolzovanie Mineralnogo Syra = Complex Use of Mineral Resources*. 2022; 321(2):47-55. <https://doi.org/10.31643/2022/6445.17>
- [5] Karboz Zha, Dossayeva SK. Study of Hydrogen Permeability of Membranes Coated with Various Metal Films (Review). *Kompleksnoe Ispolzovanie Mineralnogo Syra = Complex Use of Mineral Resources*. 2019; 310(3):48-54. <https://doi.org/10.31643/2019/6445.28>
- [6] Panichkin AV, Mamaeva AA, Derbisalin AM, Kenzhegulov AK, Imbarova AT. The Influence of Solid Solutions Compound on the Hydrogen Permeable Membranes Characteristics from Niobium and Tantalum Applied above Films. *Kompleksnoe Ispolzovanie Mineralnogo Syra = Complex Use of Mineral Resources*. 2018; 307(4):130-139. <https://doi.org/10.31643/2018/6445.39>
- [7] Khanchandani H, Gault B. Atomic Scale Understanding of the Role of Hydrogen and Oxygen Segregation in the Embrittlement of Grain Boundaries in a Twinning Induced Plasticity Steel. *Scr Mater*. 2023; 234:115593. <https://doi.org/10.1016/J.SCRIPTAMAT.2023.115593>
- [8] Safyari M, Khossossi N, Meisel T, Dey P, Prohaska T, Moshtaghi M. New Insights into Hydrogen Trapping and Embrittlement in High Strength Aluminum Alloys. *Corros Sci*. 2023, 111453. <https://doi.org/10.1016/J.CORSCI.2023.111453>
- [9] Equivalent Terminology Used in the Book Includes Internal Hydrogen Embrittlement (IHE) and Hydrogen Environment Embrittlement (HEE). 2012. <https://doi.org/10.1016/B978-0-85709-536-7.50018-0>
- [10] Tomaszewski S, Grygier D, Dziubek M. Assessment of Engine Valve Materials. *Combustion Engines*. 2023. <https://doi.org/10.19206/ce-166569>
- [11] Hamaad ASAA, Tawfik M, Khattab S, Newir A. Device for Using Hydrogen Gas as Environmental Friendly Fuel for Automotive Engine (GREEN & ECO H2). *Procedia Environ Sci*. 2017; 37:564-571. <https://doi.org/10.1016/J.PROENV.2017.03.043>
- [12] Chen G, Rahimi R, Harwarth M, Motylenko M, Xu G, Biermann H, Mola J. Non-Cube-on-Cube Orientation Relationship between M23C6 and Austenite in an Austenitic Stainless Steel. *Scr Mater*. 2022, 213. <https://doi.org/10.1016/j.scriptamat.2022.114597>
- [13] Kim HP, Park YM, Jang HM, Lim SY, Choi MJ, Kim SW, Kim DJ, Hwang SS, Lim YS. Early-Stage M23C6 Morphology at the Phase Boundary in Type 304L Austenitic Stainless Steel Containing  $\delta$  Ferrite. *Metals (Basel)*. 2022; 12(11). <https://doi.org/10.3390/met12111794>
- [14] Khanchandani H, Gault B. Atomic scale understanding of the role of hydrogen and oxygen segregation in the embrittlement of grain boundaries in a twinning induced plasticity steel. *Scr Mater*. 2023 Sep 1;234:115593. <https://doi.org/10.1016/j.scriptamat.2023.115593>
- [15] Jack TA, Moreno BD, Fazeli F, Szpunar J. Influence of Hydrogen Ingress on Residual Stress and Strain in Pipeline Steels. *Mater Charact*. 2024, 113654. <https://doi.org/10.1016/j.matchar.2024.113654>
- [16] Au M. Mechanical Behavior and Fractography of 304 Stainless Steel with High Hydrogen Concentration. No WSRC-TR-2002-00558 Savannah River Site (US). 2003;(865). <https://www.osti.gov/servlets/purl/807672>.
- [17] Bertsch KM, Nagao A, Rankouhi B, Kuehl B, Thoma DJ. Hydrogen embrittlement of additively manufactured austenitic stainless steel 316 L. *Corros Sci*. 2021 Nov 1;192:109790. <https://doi.org/10.1016/j.corsci.2021.109790>
- [18] Caskey GR. Fractography of hydrogen-embrittled stainless steel. *Scripta Metallurgica*. 1977;11(12). [https://doi.org/10.1016/0036-9748\(77\)90311-8](https://doi.org/10.1016/0036-9748(77)90311-8)
- [19] Komatsu A, Fujinami M, Hatano M, Matsumoto K, Sugeoi M, Chiari L. Straining-temperature dependence of vacancy behavior in hydrogen-charged austenitic stainless steel 316L. *Int J Hydrogen Energy*. 2021 Feb 3;46(9):6960–9. <https://doi.org/10.1016/j.ijhydene.2020.11.148>
- [20] Rieck RM, Atrens A, Smith IO. Stress corrosion cracking and hydrogen embrittlement of cold worked AISI type 304 austenitic stainless steel in mode I and mode III. *Materials Science and Technology (United Kingdom)*. 1986;2(10). <https://doi.org/10.1179/mst.1986.2.10.1066>
- [21] Saborío-González M, Rojas-Hernández I. Review: Hydrogen Embrittlement of Metals and Alloys in Combustion Engines. *Revista Tecnología en Marcha*. 2018;31(2). <https://doi.org/10.18845/TM.V3112.3620>